

General Specifications

μR10000 Recorder



GS 04P01B01-01E

The μR10000 is a compact recorder with a recording width of 100mm. The model family consists of 1, 2, 3, 4 pen and a 6 dot models. Pen model realizes continuous recording for each channel, whereas the 6-dot model realizes a high speed of 6 dot / 10 sec. The input is universal input. High reliability is realized by contact free technology, such as self-developed high withstand voltage semiconductor relays, and pen servo unit using an ultra-small stepping motors. The versatile display such as multi-channel digital display, bar graph display, flag display, DI/DO status display, and date/time display are provided with 101 × 16 VFD dot display.

The μR10000 can be used as a monitoring device and as a quality control instrument in many applications (such as process temperature monitoring, pollution, construction, furnaces, field of medical diagnosis, field of refrigerating, etc.).



μR10000 (4-pen model)

STANDARD SPECIFICATIONS

General Specifications

Construction

Mounting:

Flush Panel Mounting (vertical), mounting next to each other (horizontal and vertical).

Mounting may be inclined up to 30°, rear below front (with horizontal base).

Allowable panel thickness: 2 to 26mm

Material:

Case: Steel, front door: aluminium die casting.

Case color:

Case and door-frame: Charcoal gray light (Mansell 10B 3.6 / 0.3 or equivalent)

Door: Splash and dust-proof (based on DIN 40050-IP54).

Dimensions:

144 × 144 × 220mm (see dimensional drawings)

Weight (approx.):

1 pen	2.1kg	4 pen	2.4kg
2 pen	2.2kg	6 dot	2.5kg
3 pen	2.3kg		

Model

1, 2, 3, and 4 pen, 6 dot-model.

Input

- Inputs: DCV: Direct Current Voltage input
20mV to 50V, 1-5V range.
- TC: Thermo couple.
- RTD: Resistance Temperature Detector.
- DI: Digital Input (contact or DC Voltage, TTL level).
- DCA: Direct Current Input (using external shunt resistor (10Ω, 100Ω, 250Ω))

Measuring range: selectable per channel

Input Type	Range	Measuring Range
DC V	20 mV	-20.00 to 20.00mV
	60 mV	-60.00 to 60.00mV
	200 mV	-200.0 to 200.0mV
	2 V	-2.000 to 2.000V
	6 V	-6.000 to 6.000V
	20 V	-20.00 to 20.00V
	50V	-50.00 to 50.00V
	1-5V*1	1.000 to 5.000V

*1: Only linear scaling can be used (burnout is available)

T0101.EPS

Input	Range	Measuring Range °C	Measuring Range °F
TC	R*2	0.0 to 1760.0°C	32 to 3200°F
	S*2	0.0 to 1760.0°C	32 to 3200°F
	B*2	0.0 to 1820.0°C	32 to 3308°F
	K*2	-200.0 to 1370.0°C	-328 to 2498°F
	E*2	-200.0 to 800.0°C	-328.0 to 1472.0°F
	J*2	-200.0 to 1100.0°C	-328.0 to 2012.0°F
	T*2	-200.0 to 400.0°C	-328.0 to 752.0°F
	N*2	0.0 to 1300.0°C	32 to 2372°F
	W*3	0.0 to 2315.0°C	32 to 4199°F
	L*4	-200.0 to 900.0°C	-328.0 to 1652.0°F
	U*4	-200.0 to 400.0°C	-328.9 to 752.0°F
RTD*6	WRe*5	0.0 to 2400.0°C	32 to 4352°F
	Pt100*6	-200.0 to 600.0°C	-328.0 to 1112.0°F
DI	JPt100*6	-200.0 to 550.0°C	-328.0 to 1022.0°F
	DCV input	OFF: 2.4V less ON: 2.4V or greater	
	Contact input	Contact input ON/OFF	

*2: R, S, B, K, E, J, T, N: IEC584-1(1995), DIN IEC584, JIS C1602-1995
 *3: W: W-5% Re/W-26% Re(Hoskins Mfg. Co.), ASTM E988
 *4: L: Fe-CuNi, DIN43710, U: Cu-CuNi, DIN43710
 *5: WRe: W-3% Re/W-25% Re(Hoskins Mfg. Co.)
 *6: Pt100: JIS C1604-1997, IEC751-1995, DIN IEC751-1996
 JPt100: JIS C1604-1989, JIS C1606-1989
 Measuring current: i=1mA

T0201.EPS

Measurement Interval:

- Pen model: 125ms / channel
- Dot printing model: 1s / 6 dot (AD integration time is 20ms or 16.7ms)
2.5s / 6 dot (AD integration time is 100ms)

A / D Integration Time:

- AUTO / FIX selectable
- AUTO: 20ms (50Hz) or 16.7ms (60Hz), automatically selected depending on the power supply frequency.
- FIX: 20ms (50Hz), 16.7ms (60Hz) or 100ms (50 / 60Hz)*1 can be selected.

*1 100ms integration time: only for dot printing model (not available for 1s / 6 dot measurement interval)

TC Burnout:

- ON / OFF selectable (per channel).
- Burnout upscale / downscale selectable (per channel)
- Normal: less than 2kΩ, burnout: more than 10MΩ.
- Measuring current: approx. 10μA.

1-5V Burnout:

- Burnout: less than 0.2V

Filter:

- Pen model:
 - Signal damping: ON / OFF selectable per channel
 - Time constant : 2, 5, 10sec
- Dot printing model:
 - Moving average: ON / OFF selectable per channel
 - Moving average cycle: 2 to 16

Computation:

Differential computation:

Between any two channels, however reference channel number must be smaller than measuring channel number.
 Available for DCV, TC, and RTD range.
 Both channels must have same range.

Linear scaling:

Available for DCV, TC, RTD and DI range.
 Scaling range: -20000 to 30000
 Data display & printout range: -19999 to 30000
 Decimal point: User selectable
 Unit: User settable, up to 6 characters (alphanumerical & special characters).

Square root:

Available for DCV range.
 Scaling range: -20000 to 30000
 Data display & printout range: -19999 to 30000
 Decimal point: User selectable
 Unit: User settable, up to 6 characters (alphanumerical & special characters).
 Low level cut off: 0.0 to 5.0% of recording span

Bias addition: -10.0 to 10.0% of recording span

Recording and Printing

Recording Method:

- Pen model: Disposable felt pens, Plotter pen
- Dot printing model: 6 color wire dot.

Pen Offset Compensation:

ON / OFF selectable (Pen model only)

Effective Recording Width: 100mm

Chart:

Plain-paper Z-fold chart (16m)

Step Response Time (pen):

Approx. 1s / IEC 61143 method

Recording Period:

Pen model:
 Continuous for each channel.

Dot printing model:

- Max. 6 channel / 10sec(the shortest recording period)
- 7 to 12 channels* / 15sec(the shortest recording period)
- 13 to 18 channels* / 20sec(the shortest recording period)

* Including Math channels for the model with /M1 option

AUTO / FIX selectable

- AUTO: Analog recording interval is depending on the chart speed
- FIX: Analog recording interval is set to the shortest period

Chart Speed:

Pen model: 5 to 12000mm/h (82 increments)

Dot printing model: 1 to 1500mm/h (1mm step)

Chart Speed Change:

Speed 1, speed 2 change by remote control signals (option)

Chart Speed Accuracy:

Within ± 0.1% (for recordings longer than 1000mm, related to the grid of the chart paper)

Relation between Chart Speed and Printout:
(Pen-model)

Chart Speed	• Periodic Printout	• Alarm Printout • Message Printout • Chart Speed Change Time Printout
5 to 9mm/h	NA	Available
10 to 1500mm/h	Available	Available
1600 to 12000mm/h	NA	NA

T0301.EPS

(Dot-printing model)

Chart Speed	• Channel No. or Tag No.	• Periodic Printout	• Alarm Printout • Message Printout • Chart Speed Change Time Printout
1 to 9mm/h	Available	NA	Available
10 to 100mm/h	Available	Available	Available
101 to 1500mm/h	NA	NA	NA

T0302.EPS

Relation between chart speed and printing intervals of periodic printouts (For AUTO interval setting):
(Pen-model)

Chart Speed	Printing Interval of Periodic Printout
5 to 9mm/h	NA
10 to 18mm/h	Every 8 hours
20 to 36mm/h	Every 4 hours
40 to 72mm/h	Every 2 hours
75 to 135mm/h	Every hour
150 to 180mm/h	Every 30 minutes
200 to 320mm/h	Every 20 minutes
360 to 1500mm/h	Every 10 minutes
more than 1600mm/h	NA

T0303.EPS

(Dot-printing model)

Chart Speed	Printing Interval of Periodic Printout
1 to 9mm/h	NA
10 to 19mm/h	Every 8 hours
20 to 39mm/h	Every 4 hours
40 to 79mm/h	Every 2 hours
80 to 100mm/h	Every hour
101 to 1500mm/h	NA

T0304.EPS

Recording Colors:

Pen model:

pen1=red, pen2=green, pen3=blue,

pen4=violet, plotter pen=purple

Dot printing model:

ch1=purple, ch2=red, ch3=green, ch4=blue,

ch5=brown, ch6=black (color can be assigned to any channel)

Recording Format:

1. Analog recording:

Analog recording ON/OFF selectable for each channel of dot model

Zone recording:

Span: More than 5mm (1mm step)

Partial expanded recording:

Boundary position: 1 to 99%

Boundary value: Within recording span

2. Digital printout:

Channel (dot model only):

Channel number or TAG will be printed during analog recording. Approx. every 25mm this print will occur.

ON / OFF selectable (common for all channels)

Alarm:

At the right side of the chart, CH. No. or TAG, Type of alarm, date/time*2 of alarm ON / OFF will be printed. Time of alarm ON / OFF, time of alarm ON, OFF selectable (common for all channels).

Periodic printout contents:

Date (mm/dd/yy), time(hh:mm), measurement data of each channel, scale printout, recording color, chart speed

- Measurement data of each channel:

a. ON/OFF selectable

b. Channel No. or tag, alarm status (for instantaneous mode), measuring value (according to instantaneous mode or report mode), measuring unit (up to 6 characters)

- Scale printout:

a. ON/OFF selectable (common for all channels)

b. 0 and 100% scale value (when using partial expanded recording, boundary value is recorded)

c. Printout available in case of more than 40 mm of recording span

- Recording color:

Only for pen model (OFF selectable)

- Periodic print interval:

a. Using internal timer

b. Standard time 00:00 to 23:00(on the hour)

c. Print interval setting (AUTO/MAN)*4

AUTO: Automatically set as chart speed

MAN: 10, 12, 15, 20, 30 minute, 1, 2, 3, 4, 6, 8, 12, 24 hour

- Periodic printout mode:

Selectable from Instantaneous value mode / report mode/OFF mode

a. Instantaneous value mode:

Measuring value for each channel

b. Report mode: Selectable from MIN, MAX, AVE, MIX(MIN/MAX/AVE), SUM, INST

Report interval: Same as periodic printout interval

c. OFF mode: Periodic printout is not executed.

Message printout:

With panel key or remote control option, up to 5 messages can be printed.

Contents: Date/time*1 and message (up to 16 characters).

Record start time:

Date/time*2 will be printed when recording starts, ON / OFF selectable.

Chart speed printout:

Date/time*2 when chart speed is changed will be printed, ON / OFF selectable.

List printout*3:

Listings of range and alarm setting, etc. will be printed.

Manual printout*3:

With panel key or remote control option, measuring value will be printed.

SET UP printout*3:

Listings of settings in SET UP Mode will be printed.

*1 Selectable from hh:mm, hh:mm:ss, mm/dd hh:mm, mm/dd hh:mm:ss, mm/dd/yy hh:mm:ss, OFF.

*2 Selectable from hh:mm, hh:mm:ss, mm/dd hh:mm, mm/dd hh:mm:ss, mm/dd/yy hh:mm:ss

*3 During printout trend recording will be interrupted.

*4 According to printout settings all the items are not printed.

Display

Display Method:

VFD 101 × 16 dot matrix

15 display screens can be selected from the any of followings (default display is 6 screens)

- 1 channel digital display*1,*4: AUTO*2/MAN*3
- 2 channel digital display*1,*4: AUTO*2/MAN*3
- 4 channel digital display*4: Channel No., alarm type, measuring value are displayed
- 6 channel digital display*4: Measuring value display (only for dot model)
- 1 channel digital display*4 + 1 channel bar graph display: AUTO*2/MAN*3
- 1 channel digital display*4 + 4 channel bar graph display (only for pen model): AUTO*2/MAN*3
- 2 channel digital*4 + 2 channel bar graph display: AUTO*2/MAN*3
- 4 channel bar graph display (only for 4 pen model)
- 6 channel bar graph display (only for dot model)
- Flag display
- DI/DO display (Available for model with /R1 or /A1, /A2, /A3 option)
- Alarm status*1
- Date/time display (mm/dd/yy hh:mm)+Chart speed display
- Date/time display (mm/dd/yy hh:mm)*5
- Chart speed display*5
- Status display*1

- System display
- Display Off (light out)*1
- Split display: Upper/lower position display
- Tag 1 channel digital display*1,*4: AUTO*2/MAN*3
- Tag 2 channel digital display*4: AUTO*2/MAN*3
- Tag 1 channel digital display*4 + 1 channel bar graph display: AUTO*2/MAN*3
- Tag 1 channel digital display + 4 channel bar graph display*4 (4 pen model only)

Status display:

- Recording in progress (RECORD)
- Shared alarm display (ALARM)
- Alarm occurrence No. display (1 2 3 4 5 6)
- Chart end indicator (CHARTEND).....For the model with /F1 option
- Computation in progress(MATH).....For the model with /M1 option
- Key lock display (KEYLOCK)

*1 The displays can be specified for split display.

*2 AUTO: Channel No., alarm type, measuring value, and measuring unit (6 digit) are displayed in order of channel No.

For 1 channel digital display + 1 channel bar graph display, the unit display is 3 digit.

*3 MAN: The same contents of AUTO for the specified channel are displayed.

*4 Display updated interval can be selected from AUTO / MAN.

AUTO: 1s / 2s / 3s / 4s / 5s

MAN: 2s (pen model), same as measurement interval (dot model)

*5 The display can be specified only for split display.

Power Supply

Rated Power Voltage:

100 to 240VAC, automatically selected depending on the power supply voltage

Usable power voltage ranges:

90 to 132, 180 to 264VAC

Rated Power Frequency:

50 / 60 Hz, automatically selected

Power Consumption:

(approx.)

	100VAC Power Source	240VAC Power Source	Maximum
1-4 pen	12VA*	17VA*	40VA
6 dot	13VA*	18VA*	40VA

* : In Balance

T0401.EPS

Alarm

Number of alarm levels:

Up to four levels for each channel

Alarm types:

High and low, limits, differential high and low limits, high and low rate-of-change limits and delay high and low

Alarm delay time: 1 to 3600s

Interval time of rate-of-change alarms:

The measurement interval times 1 to 15

Display:

Alarm value is indicated as a point on the bar graph.

In occurring an alarm:

- On bar graph display, a point indicator is flashing.
- On digital display, an alarm type indicator is shown.
- A channel number of occurring alarm is displayed.
- Shared alarm display

Hysteresis:

0.0 to 1.0% (0.1% step) of recording span (only High, Low alarm, common for all channels and all levels).

Alarm indication when ALARM ACK-key is pressed:**Non-hold-type:**

Alarm display is not affected when the ALARM ACK-key is pressed.

Hold-type:

When alarm occurs, alarm indicator will start flashing. After ALARM ACK-key is pressed, indicator will show status of the alarm.

Hold-type:

Alarm ON

Alarm OFF

Indicator BLINK

Indicator ON

Indicator OFF

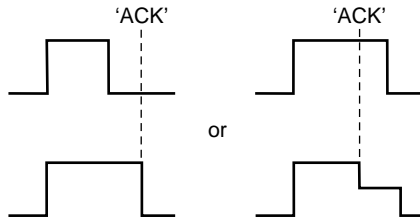
**Non-hold type:**

No action will occur when ACK-key is pressed.
ALM indicator depends on alarm status.

F0401.EPS

Other Specifications**Clock:**

With calendar function

Summer and winter time:

Summer and winter time can be set.

Clock Accuracy:

100 ppm, however not including error due to turning ON / OFF power

Panel Key Lock:

Protection by password

(Any of RCD, MENU, FEED key and functions (Alarm ACK, Math, Printout, Message, Buffer clear, Digital PRT, Pen exchange (only for pen model)) can be locked).

Internal illumination:

White LED

Memory backup:

Lithium battery to protect setting parameters.

Life is approx. ten years (at room temperature, and for standard model) and is installed inside the recorder.

Insulation Resistance:

Each terminal to ground terminal: More than 20MΩ (measured at 500VDC).

Dielectric Strength:

Power supply to ground terminal:

1500V AC (50 / 60Hz), 1 min

Contact output terminal to ground:

1500V AC (50 / 60Hz), 1 min

Measuring input terminal to ground:

1000V AC (50 / 60Hz), 1 min

Between measuring input terminals:

1000V AC (50 / 60Hz), 1 min

(except for RTD, since b-terminal is common).

Between remote control terminal to ground:

500V DC, 1min.

Mechanical noise:

Machine Noise Information Ordinance 3. GSGV, Jan. 18, 1991:

The maximum sound pressure level is equal or less than 60dB (A) according to ISO7779.

Safety and EMC standards**CSA**

CSA22.2 No.61010-1 (NRTL/C*) installation category II, measurement category II pollution degree 2

* For marking that includes NRTL, a mark with "US" (USA) printed on the right side of the CSA mark, and "C" (Canada) printed on the left side appears on this instrument.

CE**EMC directive:**

EN61326 compliance (Emission: Class A, Immunity: Annex A)

EN61000-3-2 compliant

EN61000-3-3 compliant

EN55011 compliant, Class A Group 1

Low voltage directive:

EN61010-1 compliant, installation category II measurement category II, pollution degree 2

C-Tick

AS/NZS CISPR11 compliant, Class A Group 1

Normal Operating Conditions

Power voltage: 90 to 132, 180 to 264VAC

Power frequency: 50Hz ± 2%, 60Hz ± 2%

Ambient temperature: 0 to 50°C

Ambient humidity: 20 to 80% RH (at 5 to 40°C)

Vibration: 10 to 60Hz, 0.2m/s² or less

Shock: Not acceptable

Magnetic field: Less than 400A/m (DC and 50, 60Hz)

Noise:

Normal Mode (50 / 60Hz):

DCV Peak value including signal must be less than 1.2 times the measuring range.

TC Peak value including signal must be less than 1.2 times the measuring thermal electromotive force.
 (50 / 60Hz) :
 Less than 250VAC rms
 *In case /N2 (3 leg RTD) is specified less than 200VAC rms for 6 dot model

RTD less than 50mV.
 Common Mode (50 / 60Hz):
 Less than 250VAC rms. for the whole range
 Maximum noise voltage between channels

Operating Position:
 Frontward: 0° Backward: Within 30° from horizontal

Warm-up Time:
 Min. 30 minutes after power has been turned ON.

Altitude: 2000M or less

Standard Performance

Measuring and Recording Accuracy:

(Following specifications apply to operation of the recorder under standard operation conditions: temperature 23 ± 2°C, humidity 55 ± 10%RH, power supply voltage 90 to 132V, 180 to 264V AC, power supply frequency 50/60Hz ± 1%, warm-up time at least 30 minutes, other ambient conditions like vibration should not adversely affect the recording operation).

Input	Range	Measuring (digital display)		Recording (analog)	
		Measurement Accuracy	Max. Resolution	Recording Accuracy	Resolution
DC V	20mV	± (0.1% of rdg+2 digits)	10µV	Measurement accuracy ± (0.3% of recording span)	Pen model dead band: 0.2% of recording span Dot printing model resolution: 0.1mm
	60mV		10µV		
	200mV		100µV		
	2V		1mV		
	6V	1mV			
	20V	10mV			
	50V	± (0.1% of rdg+3 digits)	10mV		
	1-5V	± (0.1% of rdg+2 digits)	1mV		
TC	R S B	± (0.15% of rdg+1°C) but R, S: 0 to 100°C, ± 3.7°C 100 to 300°C, ± 1.5°C B: 400 to 600°C, ± 2°C, and is not guranteed below 400°C	0.1°C	Measurement accuracy ± (0.3% of recording span)	Pen model dead band: 0.2% of recording span Dot printing model resolution: 0.1mm
	K	± (0.15% of rdg+0.7°C) but -200 to -100°C ± (0.15% of rdg+1°C)			
	E	± (0.15% of rdg+0.5°C)			
	J T	± (0.15% of rdg+0.5°C) but J: -200 to -100°C ± (0.15% of rdg+0.7°C)			
	N	± (0.15% of rdg+0.7°C)			
	W	± (0.15% of rdg+1°C)			
	L U	± (0.15% of rdg+0.5°C) but L: -200 to -100°C ± (0.15% of rdg+0.7°C)			
	WRe	± (0.2% of rdg+1.0°C)			
RTD	Pt100 JPt100	± (0.15% of rdg+0.3°C)	0.1°C	Measurement accuracy ± (0.3% of recording span)	Pen model dead band: 0.2% of recording span Dot printing model resolution: 0.1mm

NOTE: Recording span is 100 mm.

Accuracy in case of scaling:
 Accuracy during scaling (digits) =
 measuring accuracy (digits) × multiplier + 2 digits
 (rounded up)
 Where the multiplier = scaling span digits / recording span digits

Example:
 DCV 6V range
 recording span : 1.000 to 5.000V
 scaling span : 0.000 to 2.000
 measuring accuracy = ± (0.3% × 5V + 2 digits)
 ± (0.015V (15 digits) + 2)
 ± (17 digits)
 multiplier = 2000 digits (0.000 to 2.000 / 4000 digits
 (1.000 to 5.000V) = 0.5
 Accuracy during scaling = 17 digits × 0.5 + 2 = 11 digits
 (rounded up)

T0601.EPS

Maximum Allowable Input Voltage:
 ± 10VDC (cont.) for less than 200mVDC ranges and TC, RTD, DI ranges
 ± 60VDC (cont.) for more than 2VDC

Reference Junction Compensation:
 INT / EXT selectable (per channel)

Reference Junction Compensation Accuracy (above 0 °C):
 Type R, S, B, W, WRe: ± 1 °C
 Type K, J, E, T, N, L, U: ± 0.5 °C

Input Resistance:
 More than 10MΩ (TC, 20mV, 60mV, 200mV range)
 Approx. 1MΩ (More than 2V range).

Input Source Resistance:
 DCV, TC: 2kΩ or less
 RTD: 10Ω or less / wire (The resistance of all three wires must be equal)

Input Bias Current:
 Less than 10nA (except when burnout is specified).

Maximum Common Mode Voltage:
 250VAC rms (50 / 60Hz)

Maximum Differential Noise between Channels:
 250VAC rms (50 / 60Hz)
 200VAC rms (50 / 60Hz, for the mode / with / N2 option)

Interference between Channels:
 120dB (Input external resistance 500Ω, the deviation in the case that 60V is applied to another channel)

Common Mode Rejection Ratio:
 120dB (50/60Hz ± 0.1%, 500Ω imbalance between '-' terminal and ground)

Normal Mode Rejection Ratio:
 40dB (50 / 60Hz ± 0.1%)

Effect of Operating Conditions

Effect of Ambient Temperature:
 Effect of ambient temperature variation of 10°C.
 Digital display: Within ± (0.1% of rdg+1 digit)
 Recording: Within Digital display ± 0.2% of recording span (excluding RJC error)

Effect of Power Supply:
 Effect of variation within 90 to 132V or 180 to 264VAC in rated power supply voltage:
 (50 or 60Hz)
 Digital display: Within ± 1 digit
 Recording: Within ± 0.1% of recording span

Effect of rated power frequency variation of ± 2Hz (at 100VAC):
 Digital display: Within ± (0.1% of rdg+1 digit)
 Recording: Same as digital display

Effect of Magnetic Field:
 Effect of AC (50 / 60Hz) or DC 400AT/m field:
 Digital display: Within ± (0.1% of rdg+10 digits)
 Recording: Less than ± 0.5% of recording span

Effect of Input Source Resistance:
 Effect of Input Source Resistance variation of +1kΩ :
 DCV range:
 Ranges less than 200mV: Within ± 10 μV
 Ranges more than 2V: Within -0.1% of rdg

TC range:
 Within ± 10 μV

RTD range:
 - Effect of 10Ω per wire (resistances of three wires must be equal):
 Digital display: Within ± (0.1% of rdg+1 digit)
 Recording: Within Digital display ± 0.1% of recording span
 - Effect of difference of three wires:
 Digital display: 0.1°C per 40 mΩ (approx.) for Pt100 range.

Effect of Operating Position:
 Digital display: Within ± (0.1% of rdg+1 digit) (within 30° backwards)
 Recording: Within Digital display ± 0.1% of recording span (within 30° backwards)

Vibration:
 Effect when sine-wave motion of frequency 10 to 60Hz and acceleration of 0.2m/s² is applied to the instrument in the direction of three axes for two hours:
 Digital display: Within ± (0.1% of rdg+1 digit)
 Recording: Within Digital display ± 0.1% of recording span

Transport and Storage Conditions

No malfunction will occur under these conditions, however when returning to normal operation conditions, calibration might be necessary.
 Temperature: -25°C to 60°C
 Humidity: 5 to 95% RH (no condensation)
 Vibration: 10 to 60Hz, 4.9m/s²
 Shock: Less than 392m/s² (while being packed)

Contents of μR10000 firmware version change (R1.11)*

1. Date display type for printout/display: Selectable from below table

Format	Printout/display example	Remark
yy/mm/dd	2005/08/31	Additional format
mm/dd/yy	08/31/2005	
dd/mm/yy	31/08/2005	
dd.mm.yy	31.08.2005	
mm.dd.yy	Aug.31.2005	Default (same as before)

T0701.EPS

2. Available for replacing ribbon cassette with power ON for dot models.
 - Ribbon cassette replacement function is added within FUNC key operation.

- Available for keylock on to ribbon cassette replacement function.
- 3. /C3: RS-422A/485communication interface
Protocol: Modbus/RTU SLAVE (2-wire)
- 4. DST Setting method
Month, day of week, and week number are set.

*: The settings of above alteration can not be done with configuration software (RXA10: R1.02 or before).

OPTIONAL SPECIFICATIONS

- / A1: Alarm Output Relay (2 contacts)
- / A2: Alarm Output Relay (4 contacts)
- / A3: Alarm Output Relay (6 contacts)

When alarm occurs, output relay on rear terminal will be activated.

- AND / OR selectable.
- Energized/ deenergized selectable (common for all relays).
- Hold type/ non-hold type selectable (common for all relays).
- Reflash relay:
Alarms can be assigned to an output relay (I01-I03)
- Relay contact rating: DC 250V / 0.1A
AC 250V / 3A
- Type of relay output: NO-C-NC

Note : Alarm ACK key:

Non-Hold type:

No effect when ALARM ACK-key is pressed (no effect on output relay).

Hold type:

When ALARM ACK-key is pressed, the output relay will be reset.

Non-hold-type:

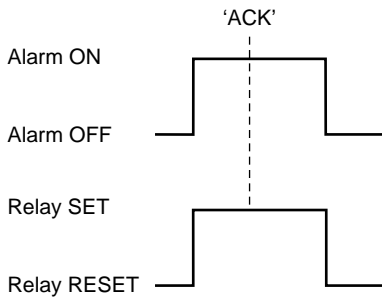

Hold-type:

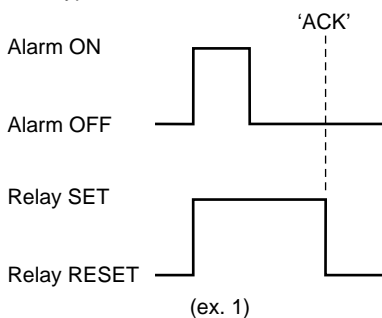

(ex. 1)

F0801.EPS

Hold-type:

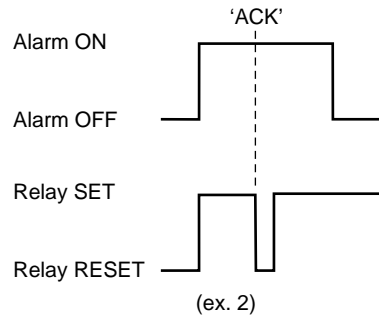

(ex. 2)

F0802.EPS

/ C3: RS-422A / 485 Communication Interface

By using this communication function, setting and control of data can be done by a host-computer. Data can also be output to the host-computer.

- Synchronization method:
start-stop asynchronous transmission
- Specifications:
Conform to EIA RS-422A / 485 standard
- Communication method:
4-wire half-duplex multi-drop connection
(1: N (N=1 to 32))
- Transfer rate:
1200, 2400, 4800, 9600, 19200, 38400bps
- Data length: 7 or 8 bit
- Stop bit: 1 bit
- Parity: Odd, even or none
- Communication distance: Up to 1.2km
- Communication mode:
ASCII (control / setting / measured data) or
Binary (measured data)

/C7: Ethernet Interface

Electrical and mechanical specifications:

Conforms to IEEE 802.3

Transmission media: 10 Base-T

Protocol: TCP, IP, UDP, ICMP, ARP

/ F1: FAIL / Chart End Detection and Output

If an error in the CPU board occurs, or when the chart reaches its end, output relay on the rear terminal will be activated. Besides, when the chart reaches its end, 'CHARTEND' indicator will be shown on the display.

Relay contact rating:

DC 250V / 0.1A, AC 250V / 3A

/ H2: Clamped Input Terminal

Using clamped input terminals as input terminal.

/ H3: Non-glare Door Glass

Provides non-reflective glass in the front door.

/ M1: Mathematical Functions

- Computation channel recording

Pen model: Measurement and computation channel can be assigned to 1-4pen.

- Dot model: ON/OFF selectable for each channel
- Zone recording
- Partial expanded recording
- Alarm for computation channel
 - Number of levels: Up to four levels for every channel (High and low limits, delay High and low)
- Number of computation channel: 8 (pen model)
12 (dot model)
- Computation expression: Up to 120 characters can be used
- Types:
 - Four arithmetic operations, square root, absolute, common logarithm, exponential, power, relational operations (>, ≥, <, ≤, =, ≠), logic operations (AND, OR, NOT, XOR)
- Constant*1: Up to 30 constants can be used
- Communication digital input*1:
 - Pen model: 8 channels
 - Dot model: 12 channels
- Remote input*1: Up to 5 remote inputs status(I/O) can be used in computation expression

*1 It cannot be used in statistical computation expression.

Statistical computation

The following computation can be executed for the specified internal timer

- Types of statistics: MAX, MIN, AVE, SUM, MAX-MIN (Totalization)
- Type of internal timer: 3 types
 - Timer types: Internal of periodic printout, absolute time, relative time

/ N1: Cu10, Cu25 RTD input

This option allows Cu10 and Cu25 RTD inputs to be added to the standard input types.

Cu10, Cu25 Measurement Range

	Input Type	Measurement Range
RTD	Cu10(GE) Cu10(L&N) Cu10(WEED) Cu10(BAILEY) Cu10 : α = 0.00392 at 20°C Cu10 : α = 0.00393 at 20°C Cu25* : α = 0.00425 at 0°C	-200 to 300°C (-328 to 572°F)

*Measuring current i=1mA

T0902.EPS

Measurement / Recording Accuracy

Input Type	Measurement Accuracy	Recording Accuracy
Cu10(GE) Cu10(L&N) Cu10(WEED) Cu10(BAILEY) Cu10 : α = 0.00392 at 20°C Cu10 : α = 0.00393 at 20°C	± (0.4% of rdg + 1.0°C)	Measurement Accuracy ± (0.3% of recording span)
Cu25 : α = 0.00425 at 0°C	± (0.3% of rdg + 0.8°C)	

T1001.EPS

/ N2: 3 Leg Isolated RTD Input

A, B, b legs are isolated input type

/N3: Expansion Inputs

This option allows 14 types inputs such as Pt50, PR40-20, PLATINEL inputs to be supported besides the standard input types.

/N3 Measurement Range

Input	Measuring Range		
TC	PR40-20	0.0 to 1900.0°C	32 to 3452°F
	PLATINEL	0.0 to 1400.0°C	32 to 2552°F
	NiNiMo	0.0 to 1310.0°C	32 to 2390°F
	W/WRe26	0.0 to 2400.0°C	32 to 4352°F
	Type N(AWG14)	0.0 to 1300.0°C	32 to 2372°F
	Kp vs Au7Fe	0.0 to 300.0K	—
RTD (Measuring contact i=1mA)	Pt25	-200.0 to 550.0°C	-328.0 to 1022.0°F
	Pt50	-200.0 to 600.0°C	-328.0 to 1112.0°F
	Ni100(SAMA)	-200.0 to 250.0°C	-328.0 to 482.0°F
	Ni100(DIN)	-60.0 to 180.0°C	-76.0 to 356.0°F
	Ni120	-70.0 to 200.0°C	-94.0 to 392.0°F
	J263*B	0.0 to 300.0K	—
	Cu53	-50.0 to 150.0°C	-58.0 to 302.0°F
	Cu100*1	-50.0 to 150.0°C	-58.0 to 302.0°F

*1: Cu100: a = 0.00425 at 0°C

T1002.EPS

Measurement / Recording Accuracy

Input	Measuring Accuracy	Recording Accuracy
PR40-20*1 0 to 450°C 450 to 750°C 750 to 1100°C 1100 to 1900°C	Not guaranteed ± (0.9% of rdg+3.2°C) ± (0.9% of rdg+1.3°C) ± (0.9% of rdg+0.4°C)	Measurement Accuracy ± (0.3% of recording span)
PLATINEL	± (0.25% of rdg+2.3°C)	
NiNiMo	± (0.25% of rdg+0.7°C)	
W/WRe26 0 to 400°C 400 to 2400°C	within ± 15.0°C ± (0.2% of rdg+2.0°C)	
Type N(AWG14)	± (0.2% of rdg+1.3°C)	
Kp vs Au7Fe 0 to 20K 20 to 300K	± 4.5K ± 2.5K	
Pt25	± (0.15% of rdg+0.6°C)	
Pt50	± (0.3% of rdg+0.6°C)	
Ni100(SAMA) Ni100(DIN) Ni120	± (0.15% of rdg+0.4°C)	
J263*B 0 to 40K 40 to 300K	± 3.0K ± 1.0K	
Cu53	± (0.15% of rdg+0.8°C)	
Cu100	± (0.2% of rdg+1.0°C)	

*1: PR40-20 : No reference junction compensation (0°C fix)

T1003.EPS

/ R1: Remote Control

5 are selectable from the below mentioned remote controls.

	Number of settings	Signal
Recording start / stop	1	edge
Chart speed change	1	level
Message printout start*1	5	trigger
Manual printout start	1	trigger
Alarm ACK	1	trigger
Time adjustment (Adjusting the time to a preset time)	1	trigger
Computation start / stop*2	1	edge
Computation reset*2	1	trigger

*1 Up to 5 messages can be set

*2 / M1 option is necessary

APPLICATION SOFTWARE

With Ethernet (/C7), RS-422A/485 (/C3), or Interface unit, µR10000 setting can be configured.

• **RXA10 Configuration Software**

System requirements:

OS: Windows 2000/XP

Processor: Pentium III/600 MHz or superior (Pentium III/800 MHz or any other superior processor is recommended.)

Memory: 256 MB min. (512 MB or larger memory is recommended)

Disk device: CD-ROM drive compatible with Windows 2000/XP

Hard disk capacity:

Free space of at least 10 MB (100 MB or larger free space is recommended)

Display unit:

A model provided with a display module compatible with Windows 2000/XP and capable of handling at least 32000 colors (a display module capable of handling at least 64000 colors is recommended)

Main functions (as a package):

Configuration software:

Configuration via communication:

Configures the station, excluding the communication setting, or sets it in set mode.

• **Interface unit (attached with RXA10 configuration software)**

Method of power supply: Power supply from µR10000

Connector type: D-Sub 9-pin plug (male)

Electrical and mechanical specifications:

Conforms to EIA-574 (9-pin EIA-232 (RS232))

RS422A/485 communication interface (/C3) and interface unit cannot work together.

Model Codes

Model Code	Suffix Code	Option Code	Description
436101			μR10000 1 pen recorder
436102			μR10000 2 pen recorder
436103			μR10000 3 pen recorder
436104			μR10000 4 pen recorder
436106			μR10000 6 dot recorder
Language	-2		English, degF & DST
Option	/A1		Alarm output relay (2 contacts)*1
	/A2		Alarm output relay (4 contacts)*1
	/A3		Alarm output relay (6 contacts)*1, *2
	/C3		RS-422A/485 communication interface *3
	/C7		Ethernet communication interface *3
	/F1		FAIL/chart end detection and output*2
	/H2		Clamped input terminal *4
	/H3		Non-glare door glass
	/M1		Computation function
	/N1		Cu10, Cu25 inputs
	/N2		3 legs Isolated RTD *4, *5
/N3		Expansion inputs *6	
/R1		Remote control 5 contacts	

Model Code	Description	OS
RXA10-01	RXA10 Configuration software	Windows 2000/XP
RXA10-02	RXA10 Configuration software (With interface unit)	Windows 2000/XP

*1: Only one of /A1, /A2, /A3 can be selected
 *2: /A3 and /F1 can not be specified together
 *3: /C3 and /C7 can not be specified together
 *4: /H2 and /N2 can not be specified together
 *5: /N2 can be specified only for dot model
 *6: 14 types inputs: Pt50 RTD, PR40-20, PLATINEL TC etc.

STANDARD ACCESSORIES

Name	1 pen	2 pen	3 pen	4 pen	6 dot	
Z-fold chart	1	1	1	1	1	
6 color ribbon cassette	-	-	-	-	1	
Disposable felt-pen cartridge	Red	1	1	1	-	
	Green	-	1	1	-	
	Blue	-	-	1	1	-
	Violet	-	-	-	1	-
Plotter pen	Purple	1	1	1	1	
Mounting brackets	2	2	2	2	2	
Instruction Manual(CD-ROM)	1	1	1	1	1	
Operation Manual	1	1	1	1	1	

SPARES/OPTIONAL ACCESSORIES

Name	Model Code (Parts No.)	Specification	
Z-fold chart	B9565AW	10 (sales unit)	
6 color ribbon cassette	B9901AX	1 (sales unit)	
Disposable felt-pen cartridge	Red	B9902AM 1 (sales unit, 3 pieces/unit)	
	Green	B9902AN 1 (sales unit, 3 pieces/unit)	
	Blue	B9902AP 1 (sales unit, 3 pieces/unit)	
	Violet	B9902AQ 1 (sales unit, 3 pieces/unit)	
Plotter pen	Purple	B9902AR 1 (sales unit, 3 pieces/unit)	
Mounting brackets	B9900BX	2 (sales unit)	
Shunt resistor	(for screw input terminal)	4159 20	250Ω ± 0.1%
		4159 21	100Ω ± 0.1%
		4159 22	10Ω ± 0.1%
	(for clamped input terminal)	4389 20	250Ω ± 0.1%
		4389 21	100Ω ± 0.1%
		4389 22	10Ω ± 0.1%

T1101.EPS

REAR TERMINAL ARRANGEMENTS

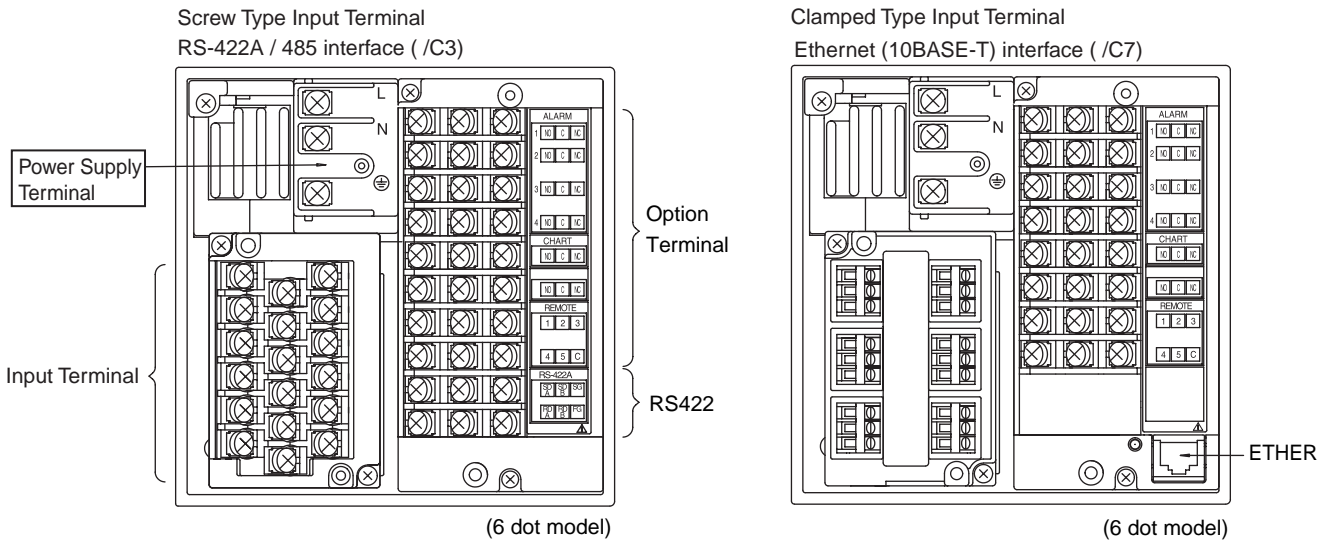

Input Terminals

4 Pen Screw Type

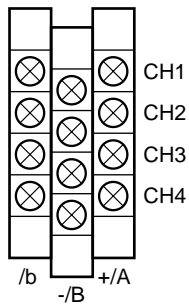

6 Dot Screw Type

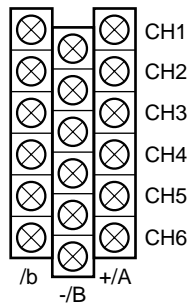

4 Pen Clamped Type (/H2)

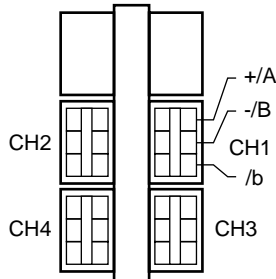

6 Dot Clamped Type (/H2)

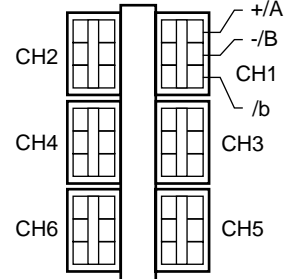

Option Terminals

/A1/F1/R1 Combination

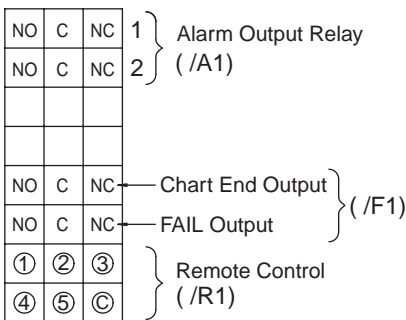

/A2/F1/R1 Combination

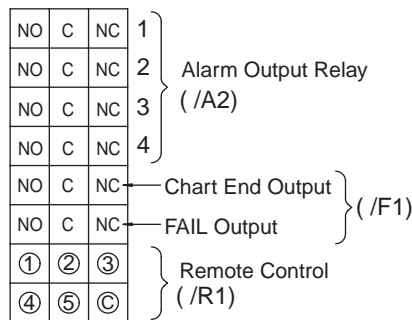

/A3/R1 Combination

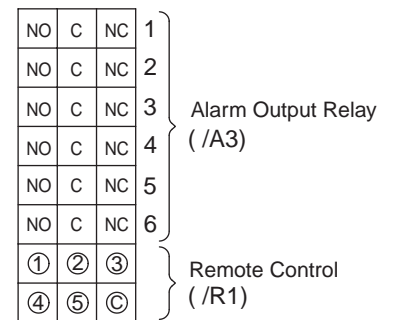

F1201Z.EPS

DIMENSION

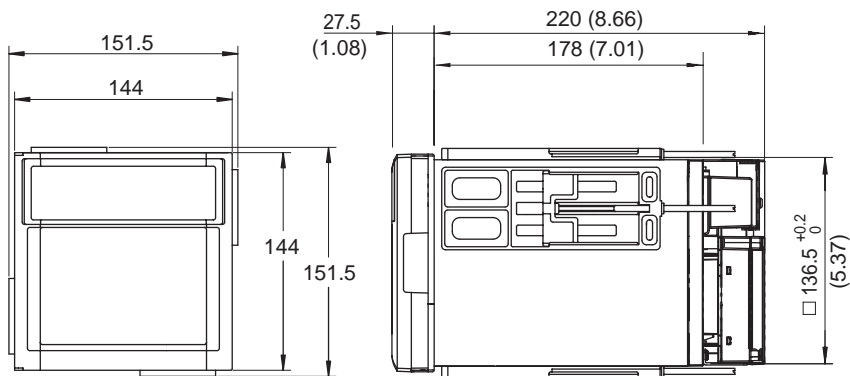
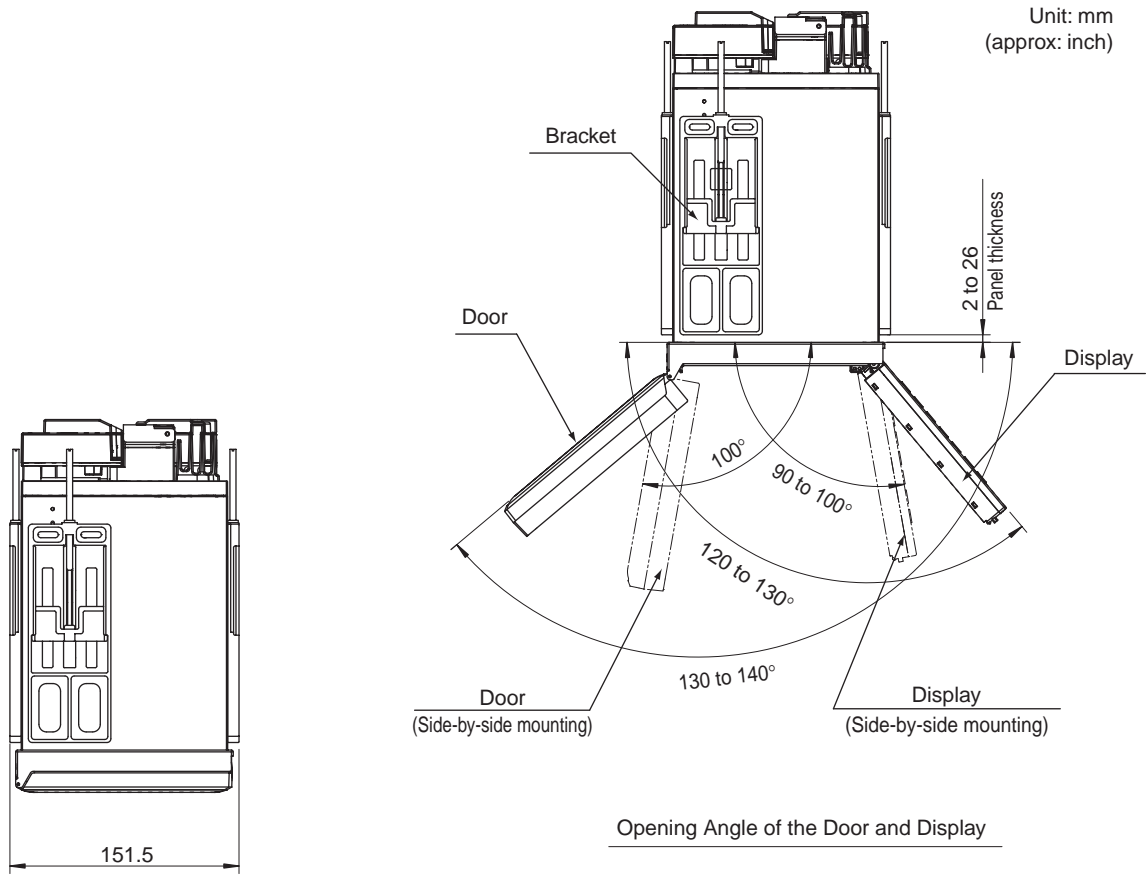

Note: If not specified, the tolerance is $\pm 3\%$. However, in case of less than 10 mm the tolerance is ± 0.3 mm.

F1301.EPS

PANEL CUTOUT & SPACING

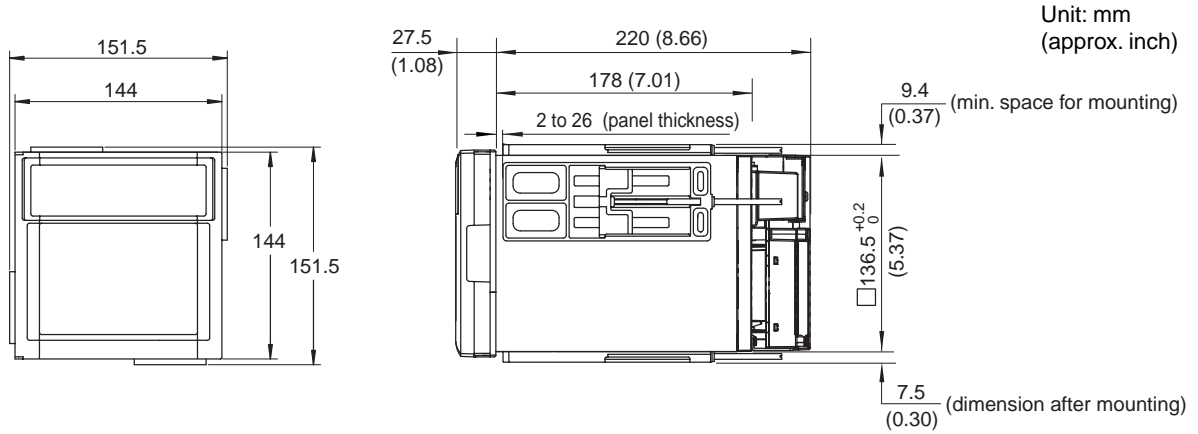

Unit: mm
(approx. inch)

Note: The μ R10000 should be mounted by only two brackets, either on the top & bottom of the recorder, or on the left & right side of the recorder.

Single-Unit Mounting

Side-by-Side Mounting (horizontally)

Side-by-Side Mounting (vertically,max.3units)

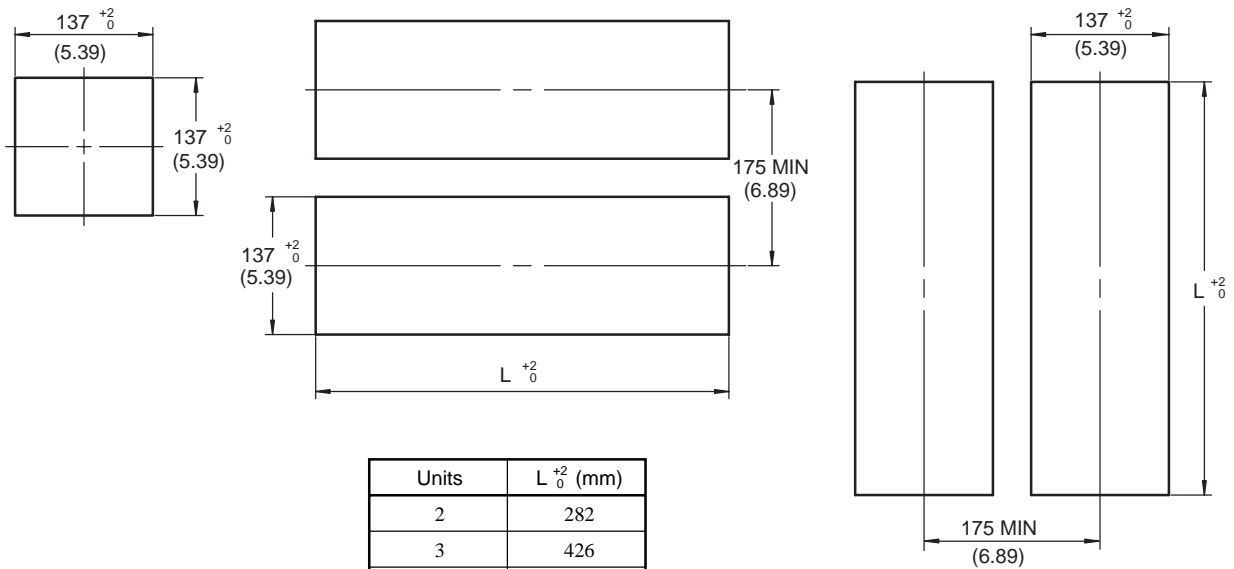

Units	L $\frac{+2}{0}$ (mm)
2	282
3	426
4	570
5	714
6	858
7	1002
8	1146
9	1290
10	1434
n	(144 × n) - 6

Weight:
 4361 01: 2.1kg
 4361 02: 2.2kg
 4361 03: 2.3kg
 4361 04: 2.4kg
 4361 06: 2.5kg

Note: If not specified, the tolerance is $\pm 3\%$. However, in cases of less than 10 mm, the tolerance is ± 0.3 mm.

F1401Z.EPS

Relationship between Bezel Height of Peripheral Equipment and Space between Measurement Instruments

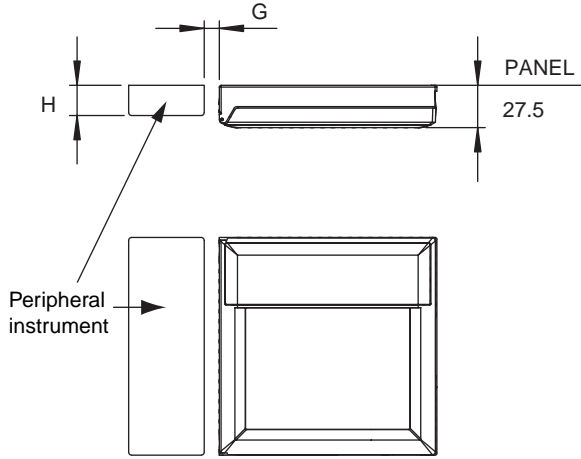

(In case mounted at the left side of $\mu R10000$)

Height of Bezel from Panel Less than H (mm)	Space More than G (mm)
20	0
24	1
28	2
32	3
More than 36 unlimited	4

Note: For instruments which do not have taper and angle R

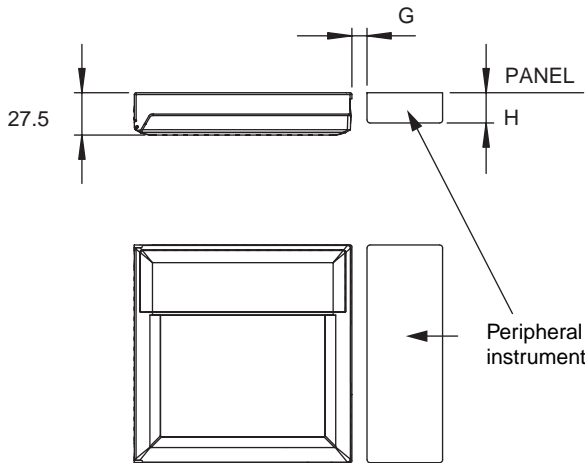

(In case mounted at the right side of $\mu R10000$)

Height of Bezel from Panel ; H (mm)	Space ; G (mm)
less than 23.5	0
more than 23.5	more than 3

Note: For instruments which do not have taper and angle R

Spacing for $\mu R10000$ and YS100 when Mounted together

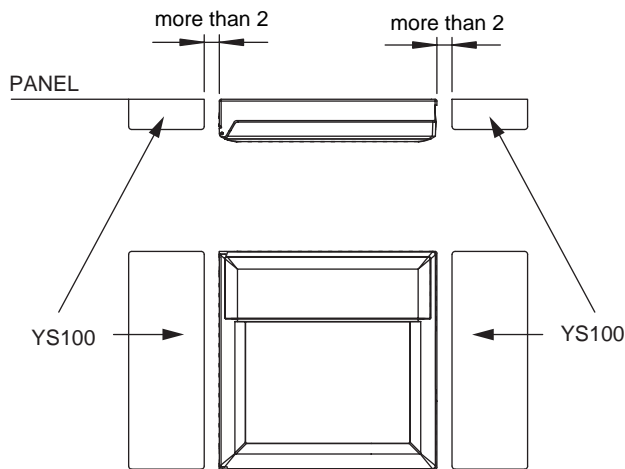

Mounting Place	Space ; G (mm)
Mount at the right side of YS100	more than 2
Mount at the left side of YS100	more than 2

F1501Z.EPS